

CLAWAR 2018: 21st International Conference on Climbing and Walking Robots and the Support Technologies for Mobile Machines, Panama City, Panama, 10-12 September 2018

## SLIDER: A BIPEDAL ROBOT WITH KNEE-LESS LEGS AND VERTICAL HIP SLIDING MOTION

KE WANG, AKSAT SHAH and PETAR KORMUSHEV

*Robot Intelligence Lab, Dyson School of Design Engineering,  
Imperial College London, UK*

*E-mail: {k.wang17, aksat.shah09, p.kormushev}@imperial.ac.uk  
www.imperial.ac.uk/robot-intelligence*

This paper introduces SLIDER, a new bipedal robot featuring knee-less legs and vertical hip sliding motion. Its non-anthropomorphic design has several advantages over the conventional anthropomorphic leg design. The lack of knees reduces the overall leg weight to only 3 kg and also reduces the moment of inertia of the leg rotation. SLIDER's ultra-lightweight legs make it suitable for agile locomotion. To test the design, we created a dynamic model of SLIDER in Gazebo and implemented a two-stage walking pattern generator, achieving a walking speed of 0.18 m/s in simulation. A physical prototype of SLIDER is currently under construction for real-world testing.

*Keywords:* Bipedal Walking, Legged Robot Design, Gait Pattern Generation

### 1. Introduction

Legged robots have advantage over wheeled ones because they can operate on rough terrain. In recent years legged robots have attracted a lot of attention and the research on legged robots has significantly intensified with a number of advanced robots being produced, including Atlas (2), Cassie (3), and TORO (5). However, most of the current legged robots still use the conventional anthropomorphic design, in which the knee actuator is mounted somewhere on the thigh, making the leg relatively heavy. This design either limits the robot's ability to perform agile locomotion (jumping, hopping, fast stepping etc.) or needs powerful motors to accomplish these motions (2) (6). We introduce our bipedal robot SLIDER, which has knee-less legs and vertical hip sliding motion. This new and non-anthropomorphic design enables SLIDER to have very lightweight legs and to perform agile locomotion with relatively small power. Hodgins et.al (7) made a simple planar biped utilizing the idea of straight legs, but that robot only has three de-

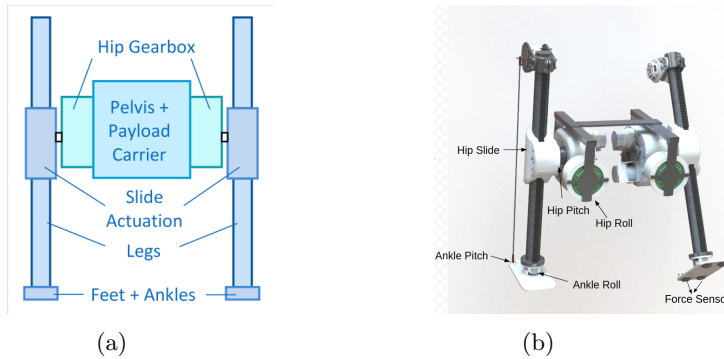

Fig. 1: An overview of SLIDER (a) Diagram of the SLIDER concept. (b) A rendering CAD model of SLIDER, showing all degrees of freedom

degrees of freedom (DOF) and lacks the hip roll and also the ankle actuation. Schaft (4) released a video with a knee-less leg design, however the design details are unknown. To the best of our knowledge, there is no existing bipedal robot design similar to SLIDER in the published research.

The purpose of building SLIDER is to explore novel designs as well as novel actuation mechanisms for bipedal robots. A second motivation is that SLIDER can serve as an experimental platform for developing control and machine learning algorithms for agile locomotion. To validate SLIDER's design, we created a dynamics model in Gazebo and implemented a two-stage walking pattern generator developed by Przemyslaw et. al (9), making SLIDER walk very stably at 0.18 m/s in simulation.

This paper is organized as follows: Section 2 gives an overview on SLIDER's mechanical design, also this section compares SLIDER's design with the anthropomorphic leg design. In Section 3, we briefly outline the gait pattern generation used for SLIDER walking and describe the result in simulation. In Section 4 we conclude the paper and give the future work.

## 2. Overview of SLIDER's Design

SLIDER is a bipedal walking robot with ultra-lightweight legs. It has a height of 96 cm and a width of 50 cm, with a total weight of only 18 kg, an overview of the robot is shown in Fig 1a. Currently each leg has 4 DOF: hip pitch, hip roll, vertical hip slide and ankle pitch, resulting in 8 DOF in total, as shown in Fig 1b. Compared with the conventional anthropomorphic leg, SLIDER's leg doesn't have knees and has a vertical hip sliding motion.

## 2.1. Mechanical Design

Table 1: SLIDER joint specifications

Joint	Gear Ratio	Gearbox Type
Hip Pitch	1:24	Spur gear
Hip Slide	1:4	Spur gear and belt
Hip Roll	1:36	2 stage cycloid
Ankle Pitch	1:16	1 stage cycloid

The pelvis is located at the center, holds the electronics and carries the payload. The hip gearbox is connected with the pelvis and the leg, which houses the motors and transmissions for the hip pitch joint and the vertical hip slide joint. The hip slide joint has a gear ratio of 1:6 and is actuated using a pulley and tensioned belt. The hip pitch joint is achieved with a gear ratio of 1:24 using a second, concentric shaft, bolted onto the side of the leg. Figure 2a shows the inner view of the gearbox and illustrates the transmission of hip slide and hip pitch. To make the design of SLIDER compact and to directly drive and swing the gearbox, we placed the hip roll on the st side of the gearbox, as is shown in Figure 2b and Figure 1b. A stationary bracket holds the hip roll motor and the transmission in place. A direct cycloidal drive with a ratio of 1:36 is employed in the hip roll transmission, chosen for shock handling and to minimize the bracket length. Furthermore, this hip roll design is also easily adaptable to integrate hip yaw, which will be potentially added.

To minimize the weight of the robot we use carbon fibre rods for the whole leg, which weights only 3 kg. The robot's hip sliding mechanism is inspired by the pulley based linear actuator: two timing belts are adhered at two sides of each leg, turning the leg into a two-sided rack in configuration with several pinions on either side. A 3D printed casing houses three pinions used for moving along the belt and the casing is connected with the inner shaft from the hip gearbox, as is shown in Figure 3a. Using a timing belt is more lightweight and the three-pinion configuration lets pinions get more contact with the belt and avoid the skipping of belt teeth.

The ankle pitch actuation is implemented by a parallel rod driven mechanism which is similar to the ankle pitch design of ASIMO (6). One rod is attached to the back of the foot. By moving the rod the ankle pitch angle can be adjusted, as is shown in Figure 3b. The feet are 3D printed and have

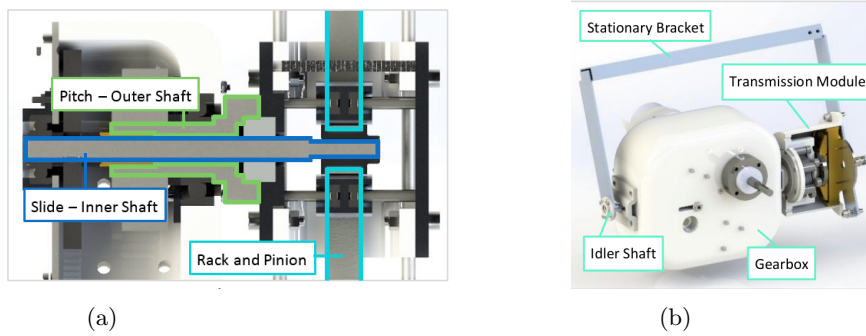

Fig. 2: (a) The inner view of the hip gearbox, it shows the transmission of vertical hip slide and hip pitch. (b) A side view of the gear motorbox and the hip roll transmission.

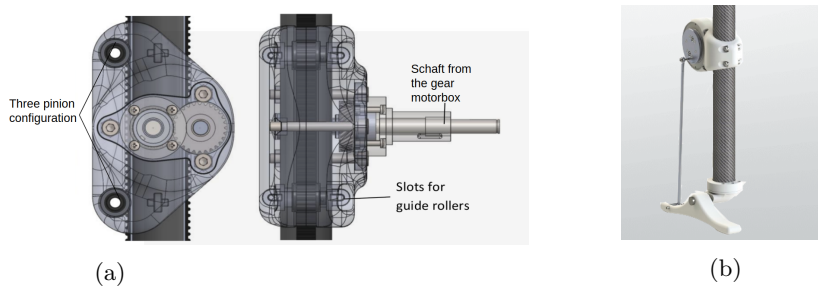

Fig. 3: (a) The pulley belt vertical hip slide design which has a three pinion configuration. (b) The rendering of the 1 DOF ankle.

an elongated shape with a length of 20cm. See Table 1 for a summary of all joint specifications.

## 2.2. Comparison of SLIDER's design with conventional anthropomorphic bipedal robot design

The novel mechanical design of SLIDER, which has knee-less legs and vertical sliding motion, has several advantages over the conventional anthropomorphic leg design. In the SLIDER design we put both hip pitch joint and vertical hip slide joint off the leg and in the pelvis, and straight legs are used instead of the anthropomorphic legs which have knees. With this design we reduce 1 DOF of the leg and remove the need for having the motor and the

Table 2: Comparison of the SLIDER design with the anthropomorphic bipedal robot design

	Anthropomorphic Design	SLIDER Design
DOFs on the leg	2 (1 on the knee and 1 on the ankle)	1 (1 on the ankle)
Vertical Compliance with Straight Legs	No	Yes
Occurrence of Singularity	When legs are straight	None
Required joint range of ankle pitch	Large	Small
Compactness of the Hip	More compact	Less compact
Social Acceptance	Easier	Harder

transmission for the knee, thus making the leg more lightweight. Moreover, while the knees on anthropomorphic legs require a compact transmission design which is expensive, the cost can be reduced. Another major advantage of SLIDER is that it has vertical compliance even if the leg is straight. This is not possible with conventional anthropomorphic bipedal robot design. Even if passive compliance is used (e.g. springs in the knee joints (11) (12)) when the leg is straight the impact force is transmitted directly to the hip, bypassing the knee springs. This means that the cushioning effect of the springs is lost when the leg is straight. In comparison, by adding a spring on the vertical hip slide joint of SLIDER, the robot can have the vertical compliance at any configurations of the leg. Furthermore, the straight leg of SLIDER also avoids the problem of singularity which happens to the conventional anthropomorphic bipedal robots when they stretch their legs fully.

There are more benefits of using the novel mechanical design: the required joint range of SLIDER's ankle pitch motion during walking is smaller than that of the anthropomorphic robots. The geometric compactness of SLIDER's straight legs makes SLIDER less prone to hit stairs than the anthropomorphic robots in the task of stair climbing.

We have to mention that there are drawbacks of the new design of SLIDER. There may be a problem with the social acceptance of the robot, because it is less human-like. Furthermore, while the design of SLIDER simplifies the structure of the leg, it makes the structure of the hip more complex by adding the vertical hip sliding joint. In addition, the straight legs of SLIDER have no knees to bend, making SLIDER harder to stand up after falling. Nevertheless, the knee-less leg design enables SLIDER to

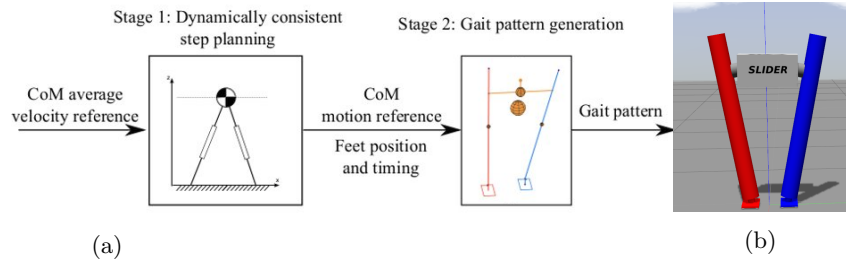

Fig. 4: (a) Overview of the flow of the two-stage pattern generation. The input to the system is an average CoM velocity during individual steps. The first stage uses Linear Inverted Pendulum model to plan the position of feet in sagittal and frontal plane, as well as step time. The second stage based on these information and uses more accurate Multi-Body System model to generate the final gait pattern. (b) the SLIDER simulation in Gazebo.

have lighter legs, making it better equipped to agile locomotion. Table 2 summarizes the difference between the SLIDER design and the conventional anthropomorphic bipedal robot design.

### 3. Control Strategy and Simulation Result

This section introduces the walking controller implemented for SLIDER. For generating walking gaits we used a two-stage dynamically consistent procedure (9) which is shown in Fig 4a.

At the first stage, given the average velocity of Center of Mass (CoM) as input, a simplified Linear Inverted Pendulum (LIP) model is used for step planning of foot position in frontal and sagittal plane as well as for tuning the step time.

The location of foot in time and the CoM trajectory generated from the first stage is then passed to the second stage which generates reference joint trajectories of SLIDER. At the second stage we used the Multi-Body System (MBS) model which approximates the system more accurate than the LIP model. Firstly the Zero Moment Point (ZMP) is calculated by the following equation:

$$ZMP_x^{ref} = x - \frac{z}{g} \ddot{x}$$

where  $ZMP_x^{ref}$  is the reference ZMP at x direction. Then a preview controller developed by Kajita et.al (8) (10) is used to compensate the discrepancies between the simplified LIP model and MBS model. The reference

trajectories computed from the preview controller are used as an input to the inverse kinematics which eventually calculates the individual reference joint position. A PD controller is used in each joint to follow the reference trajectory.

To validate the walking capability of SLIDER, we simulated the dynamics of SLIDER in MATLAB. Results show that SLIDER's ZMP has little difference with the referenced ZMP, indicating the chosen control method working well for SLIDER. Moreover, we created a model in Gazebo which has the same kinematic and dynamic properties as the physical version of SLIDER, see Figure 4b. By employing the same control strategy mentioned above, the robot can walk stably with a speed of 0.18 m/s in Gazebo simulation. A video of this walk is available at (1).

#### 4. Conclusion

This paper introduces our ongoing work on SLIDER: a new bipedal walking robot with knee-less legs and vertical hip sliding motion. Its mechanical design is described and a comparison with the conventional anthropomorphic design shows that SLIDER has much lighter legs which is suitable for agile locomotion. Moreover, we also show that by using a two-stage gait pattern generator SLIDER can walk stably in simulation.

In the future, we will continue building the physical robot prototype and test it in the real world. Also, we plan to add an additional degree of freedom in the ankle (roll) and in the hip (yaw). Furthermore, force sensors will be added on the bottom of the feet for calculating the center of pressure. ZMP feedback will be added to the control loop for online gait generation and the controller will be implemented on the physical robot.

#### References

1. The SLIDER robot walking in a Gazebo simulation.  
<http://www.imperial.ac.uk/robot-intelligence/robots/slider/>
2. Boston Dynamics: Atlas, The next generation. <https://www.youtube.com/watch?v=rV1hMGQgDkY&t=9s>
3. Cassie, next generation robot. <https://www.youtube.com/watch?v=Is4JZqhAy-M&t=99s>
4. The Schaft robot. <https://www.youtube.com/watch?v=iyZE0psQsX0>
5. Johannes Engelsberger, Alexander Werner, Christian Ott, Bernd Henze, Maximo A. Roa, Gianluca Garofalo, Robert Burger et al. "Overview of the torque-controlled humanoid robot TORO." In Humanoid Robots

## 8 REFERENCES

- (Humanoids), 2014 14th IEEE-RAS International Conference on, pp. 916-923. IEEE, 2014.
6. Kamioka, T., Kaneko, H., Kuroda, M., Tanaka, C., Shirokura, S., Takeda, M., Yoshiike, T. "Dynamic gait transition between walking, running and hopping for push recovery." Humanoid Robotics (Humanoids), 2017 IEEE-RAS 17th International Conference on. IEEE, 2017.
  7. Jessica Hodgins. "Legged robots on rough terrain: experiments in adjusting step length." Robotics and Automation, 1988. Proceedings., 1988 IEEE International Conference on. IEEE, 1988.
  8. Kajita, S., Kanehiro, F., Kaneko, K., Fujiwara, K., Harada, K., Yokoi, K., Hirukawa, H. "Biped walking pattern generation by using preview control of zero-moment point." Robotics and Automation, 2003. Proceedings. ICRA'03. IEEE International Conference on. Vol. 2. IEEE, 2003.
  9. Przemyslaw Kryczka, Petar Kormushev, Nikos Tsagarakis, Darwin G. Caldwell. "Online Regeneration of Bipedal Walking Gait Optimizing Footstep Placement and Timing". In Proc. IEEE/RSJ Intl Conf. on Intelligent Robots and Systems (IROS 2015), Hamburg, Germany, 2015.
  10. Kajita, S., Kanehiro, F., Kaneko, K., Yokoi, K., Hirukawa, H. "The 3D Linear Inverted Pendulum Mode: A simple modeling for a biped walking pattern generation." Intelligent Robots and Systems, 2001. Proceedings. 2001 IEEE/RSJ International Conference on. Vol. 1. IEEE, 2001.
  11. Petar Kormushev, Barkan Ugurlu, Darwin G. Caldwell, Nikos Tsagarakis. "Learning to exploit passive compliance for energy-efficient gait generation on a compliant humanoid." Autonomous Robots (2018): 1-17.
  12. Petar Kormushev, Barkan Ugurlu, Luca Colasanto, Nikos Tsagarakis, Darwin G. Caldwell. "The anatomy of a fall: Automated real-time analysis of raw force sensor data from bipedal walking robots and humans." Intelligent Robots and Systems (IROS), 2012 IEEE/RSJ International Conference on, IEEE, 2012.